



TAI-SAW TECHNOLOGY CO., LTD.

No. 3, Industrial 2nd Rd., Ping-Chen Industrial District,
Taoyuan, 324, Taiwan, R.O.C.

TEL: 886-3-4690038 FAX: 886-3-4697532

E-mail: tstsales@mail.taisaw.com Web: www.taisaw.com

Approval Sheet For Product Specification

Issued Date: 05/06/2005

Product Name: SMD6x3.5 12.000 MHz Crystal Resonator

TST Part No.: TZ0635A

Customer Part No.: _____

Company: _____
Division: _____
Approved by : _____
Date: _____

Checked by: _____ Robert Chang

Approved by: _____ TF Yang

Date: _____ 05/06/2005



TAI-SAW TECHNOLOGY CO., LTD.

No. 3, Industrial 2nd Rd., Ping-Chen Industrial District,
Taoyuan, 324, Taiwan, R.O.C.

TEL: 886-3-4690038 FAX: 886-3-4697532

E-mail: tstsales@mail.taisaw.com Web: www.taisaw.com

12.0000 MHz Crystal Resonator

MODEL NO.: TZ0635A

REV. NO.: 1.0

RoHS Compliant
Lead-free soldering

Electrical Specifications:

	Specification
Nominal Frequency	12.0000 MHz
Mode of Vibration	Fundamental
Storage Temperature Range	-40°C to +85°C
Operating Temperature Range	-10°C to +60°C
Frequency Stability over Operating Temperature	+/-50 ppm
Frequency Make Tolerance	+/-50 ppm @ 25°C +/- 3°C
Max. Value of the Series Resistor	50 Ω max.
Max. Value of the Parallel Capacitor	7 pF
Drive Level	100 uW nominal
Load Capacitance-CL	16.0 pF
Aging	+/-5.0 ppm/year @25°C
Marking	Laser marking
Insulation Resistance	500M Ω min at DC 100V

Mechanical Dimensions (mm):	Marking:
<p>Connection (Top View)</p>	<div style="border: 1px solid black; border-radius: 15px; padding: 10px; text-align: center;"> <p>12.000</p> <p>635 (T) ZD</p> </div> <p>“Z” stand for product code and “D” for date code</p>

PACKING:

1. REEL DIMENSION (Unit: mm)

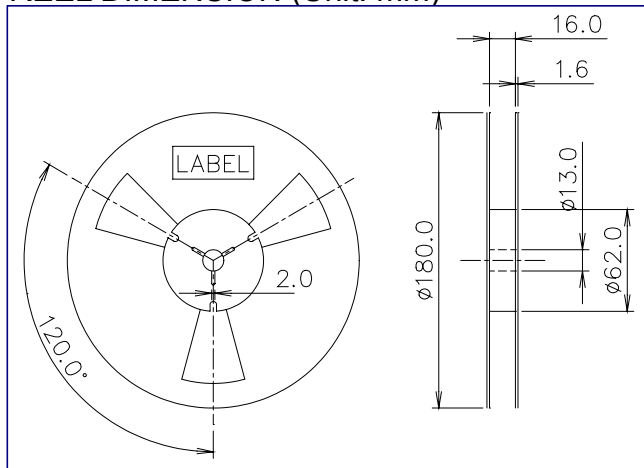

2. TAPE DIMENSION (Unit: mm)

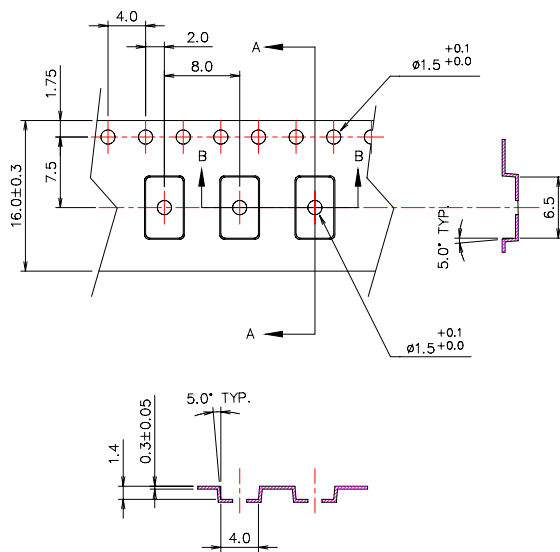

3. PACKING DIRECTION

The product code of marking should be close to the hole of tape.

Product Code Table

Year	2001	2002	2003	2004
	2005	2006	2007	2008
Product Code	Z	z	<u>Z</u>	<u>z</u>

Date Code Table

WK01	WK02	WK03	WK04	WK05	WK06	WK07	WK08	WK09	WK10	WK11	WK12	WK13
A	B	C	D	E	F	G	H	I	J	K	L	M
WK14	WK15	WK16	WK17	WK18	WK19	WK20	WK21	WK22	WK23	WK24	WK25	WK26
N	O	P	Q	R	S	T	U	V	W	X	Y	Z
WK27	WK28	WK29	WK30	WK31	WK32	WK33	WK34	WK35	WK36	WK37	WK38	WK39
a	b	c	d	e	f	g	h	i	j	k	l	m
WK40	WK41	WK42	WK43	WK44	WK45	WK46	WK47	WK48	WK49	WK50	WK51	WK52
n	o	p	q	r	s	t	u	v	w	x	y	z